

PROYECTO PREGUNTA  
QUESTION PROJECT  
PROJETO PERGUNTA  
FRAGUE PROJEKT

2  
MIL M  
\*2013  
2022

¿POR  
QUE?

PROYECTO PREGUNTA ES UNA HERRAMIENTA  
SENSIBLE QUE NO DA RESPUESTAS.

A B C C

DAS FRAGEPROJEKT IST EIN  
SENSIBLES INSTRUMENT  
WELCHES KEINE ANTWORTEN LIEFERT.

QUESTION PROJECT, IS A  
SENSITIVE TOOL THAT DOES NOT GIVE ANSWERS.





Á B C D E F G H I J K L M N  
Ñ Ó P Q R S T U V W X Y Z = ?

WHAT WOULD YOU ASK



WHERE

ARE WE

GOING

?



SOMMES - NOUS LES BIENVENU·E·S?





WAS WILLST DU DEIN BESUCHER ANS VORTIT IRT ?

NSV

D

TIT

IRT

?

DEMOCRACY ?





DO YOU SEE A BORDER?

SAFETY BOAT



**#PROYECTO PREGUNTA**  
 ¿PAPA VAS A VENIR PARA MI CUMPLEAÑOS MAÑANA?  
 ¿QUÉ LE PREGUNTARÍAS A TU PADRE O A TU MADRE?



**#PROYECTO PREGUNTA**  
 ¿ME PODRÍAS RESPONDER?  
 ¿QUÉ LE PREGUNTARÍAS A TU GOBIERNO?



**#PROYECTO PREGUNTA**  
 ¿POR QUÉ NO VAMOS AL ESTADIO?  
 ¿QUÉ LE PREGUNTARÍAS A TUS VECINOS?  
 NOMBRE Roberto Armas EDAD 55 HORA 15:45



**#PROYECTO PREGUNTA**  
 ¿POR QUÉ LA LEY 20070?  
 ¿QUÉ LE PREGUNTARÍAS A TU CIUDAD?  
 NOMBRE Renzo EDAD 18



WHAT QUESTION IS URGENT TO ASK?  
¿QUÉ PREGUNTA ES URGENTE HACER?

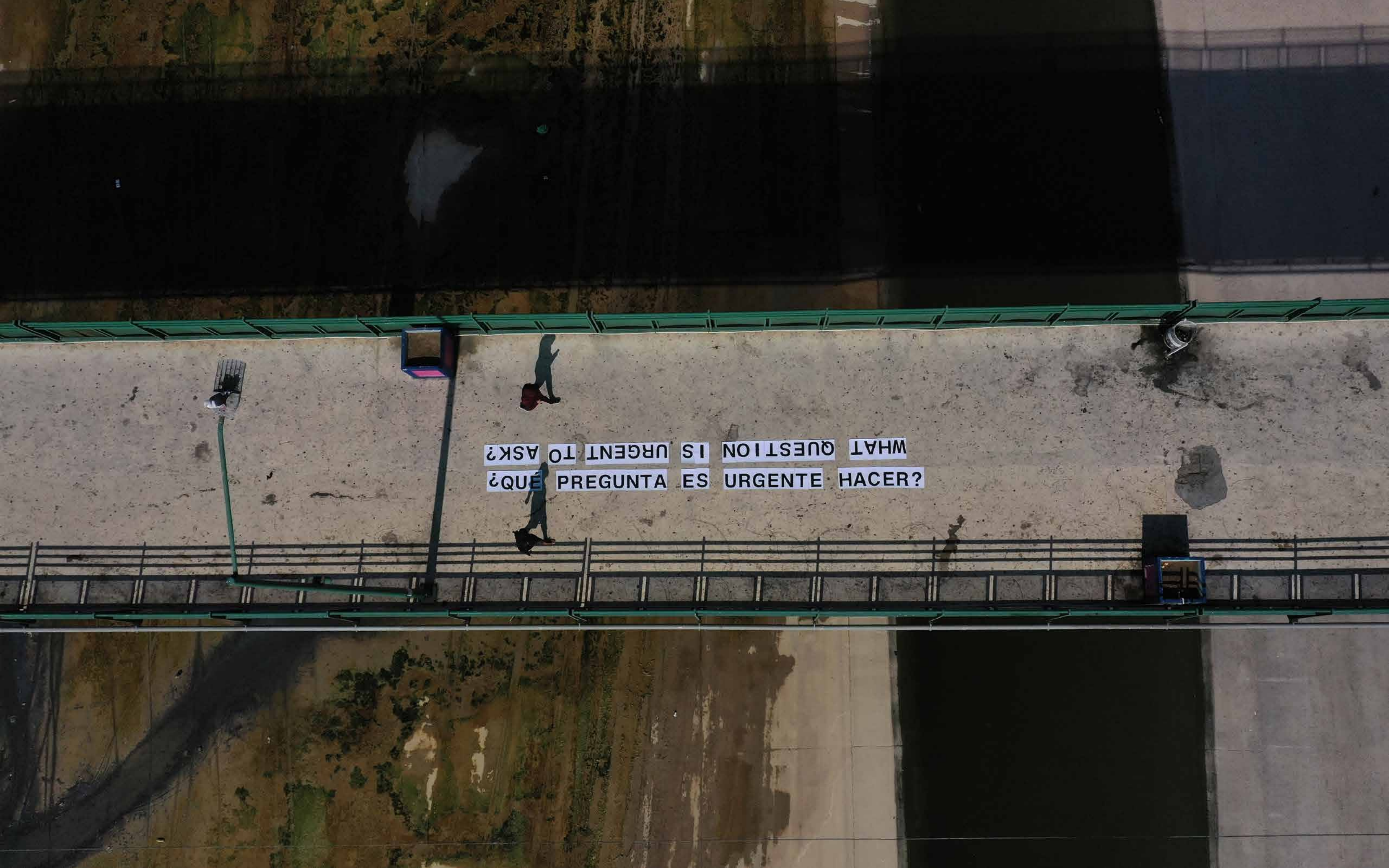



WILL

HUMANS

BE

THERE?



# WHY

Prologue



How is asking a part of your practice?  
Thus, I try to ask questions that will raise more  
questions.

Luis Camnitzer

Location:  
MX/US Border, Tijuana, México

Image question:  
An urgent question by Luis Camnitzer

# ASK?

What Question is Urgent to Ask? – MiIM2

ANSWERS ARE DIRECTED TOWARDS THE PAST.

QUESTIONS  
OPEN UP THE  
FUTURE.



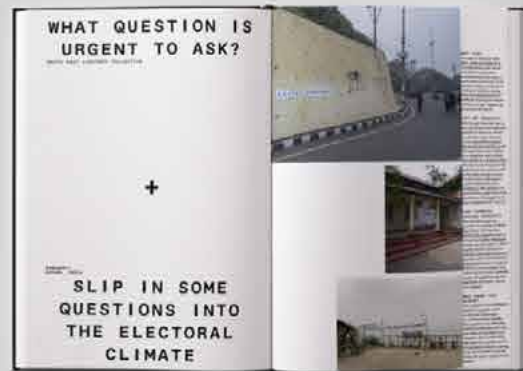
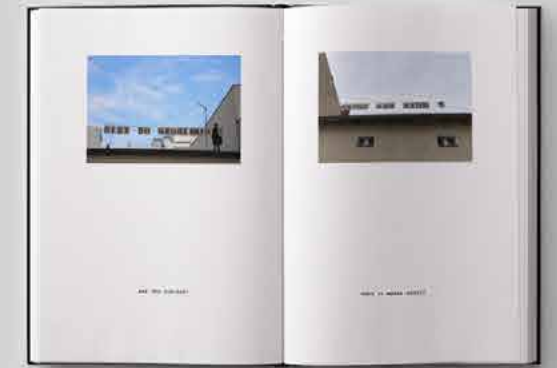
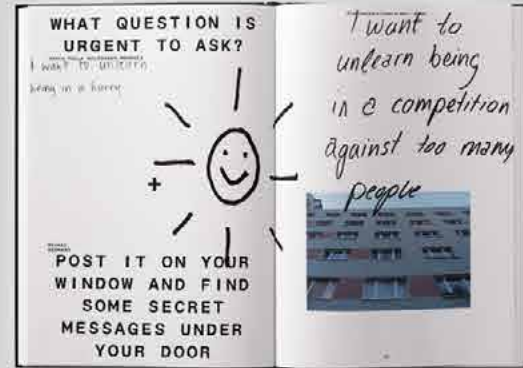
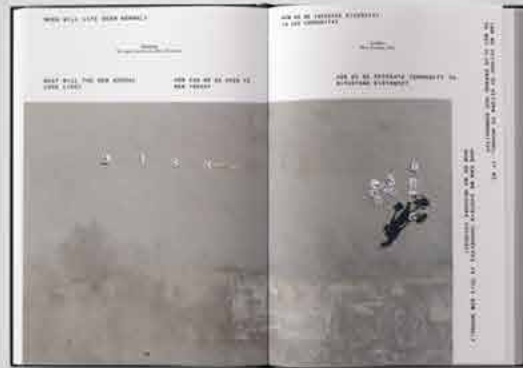
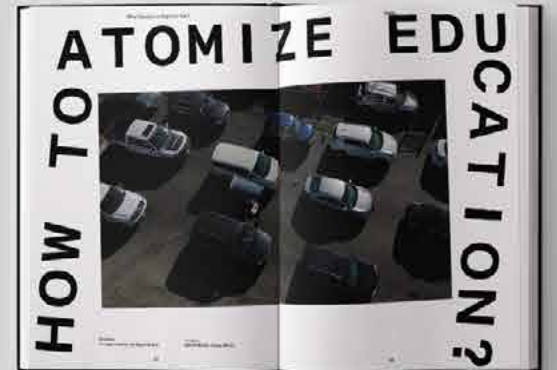
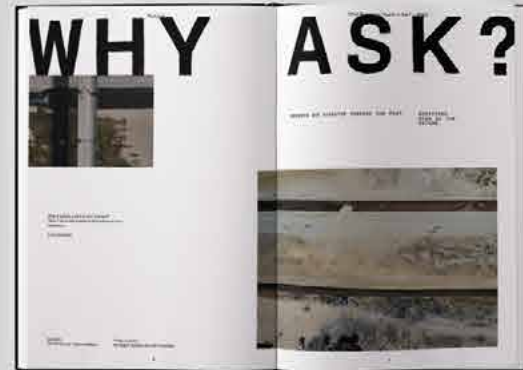
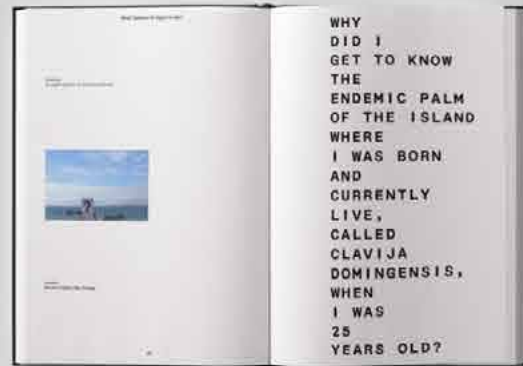

# THE BOOK OF URGENT QUESTIONS

BERLIN  
2021

HUMBOLDT FORUM

WARUM?

Länge 47,31  
Breite 6,37  
Personen 250

WHY?





WHY ISN'T ALL THAT RESTITUTED?

WHERE IS THE PALACE OF THE REPUBLIC?

RESTAURANT

WO IST DER PALAST  
DER REPUBLIK GEBLIEBEN?



WO SIND DIE FRAUEN?

HUMBOLDT  
FORUM



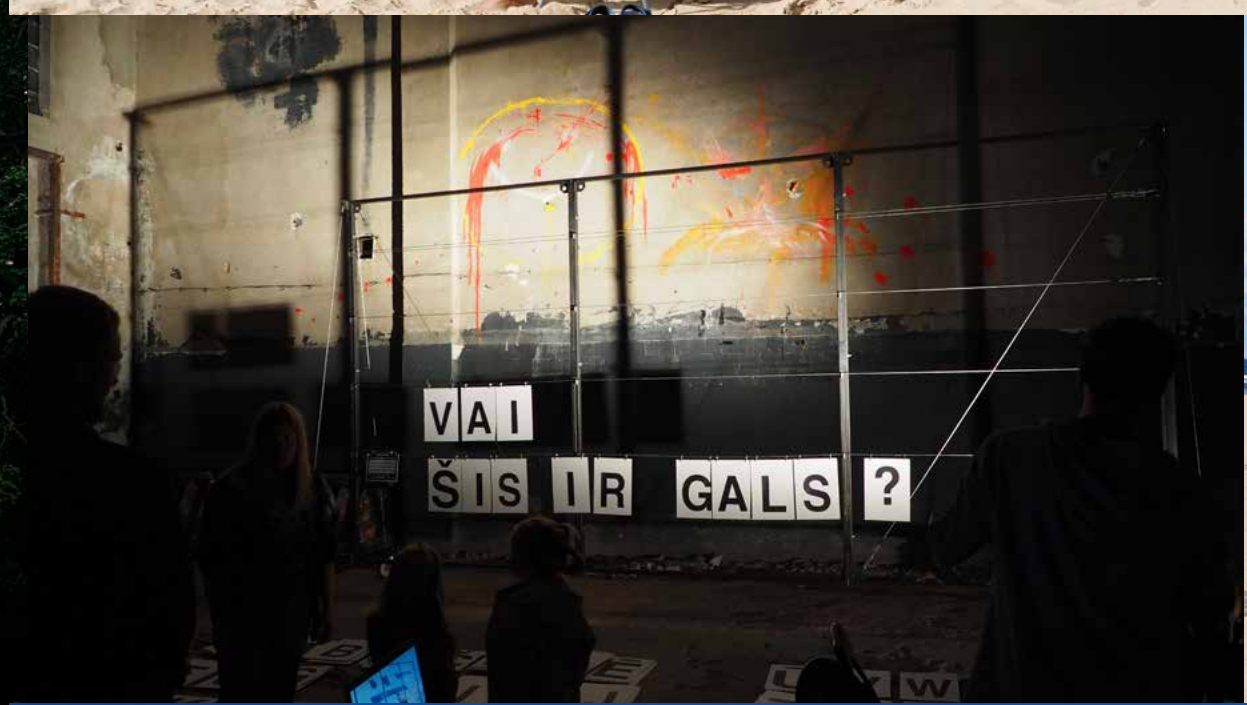

R I G A



WHY?

¿QUE PREGUNTA ES  
URGENTE HACER  
EN UN ESCENARIO  
VACÍO? WHAT  
QUESTION IS  
URGENT TO ASK IN  
AN EMPHATIC STAGE?

¿SOY UN EDIFICIO FANTASMA?

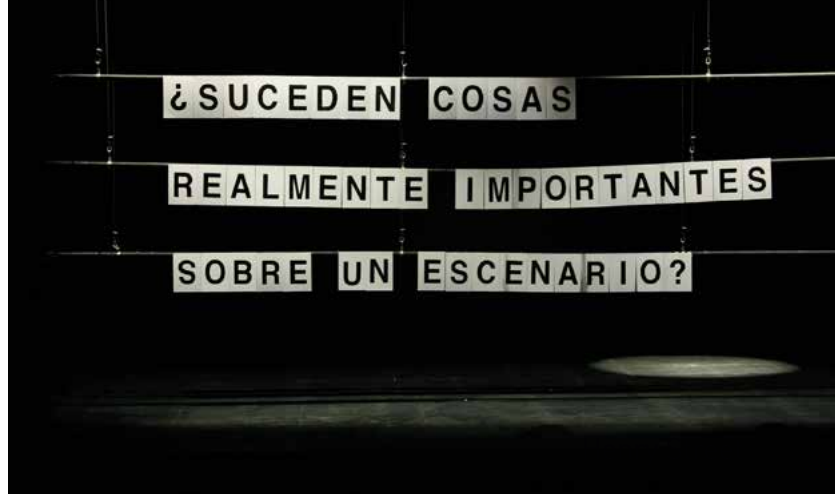
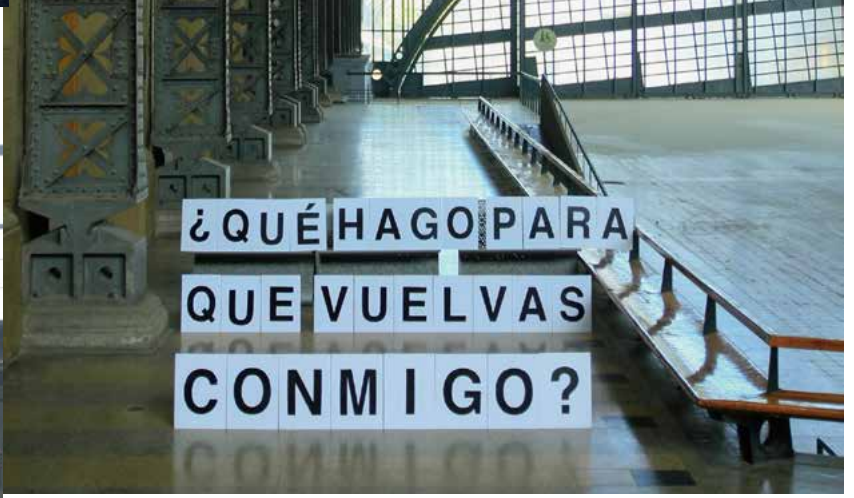
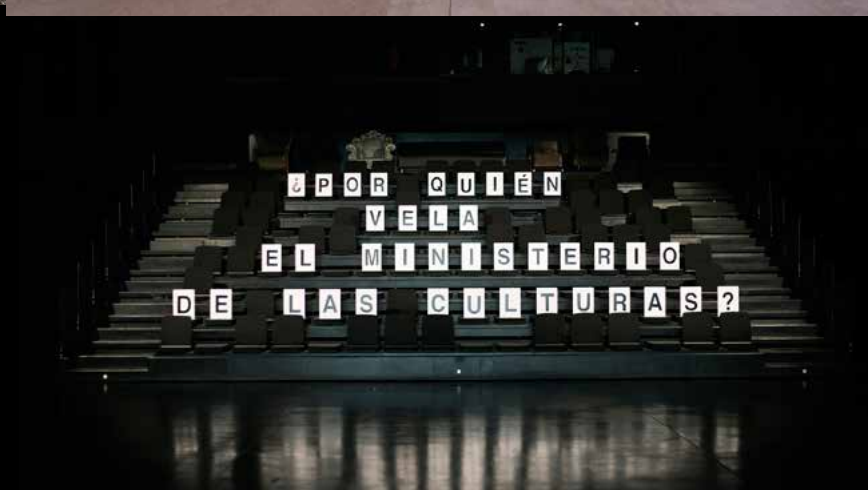



SALA HIDORA AGUIRRE  
SALA CARLOTTA PUS  
CAFETERIA

SALA DE LAS ARTES

¿TE IMAGINAS UN ENCIERRO SIN ARTE?

SANTIAGO 2021



**¿QUE PREGUNTA ES URGENTE HACER?**  
**WHAT QUESTION IS URGENT TO ASK?**

**¿QUÉ ES LA  
DIGNIDAD?**

**SANTIAGO PANDEMICO 2020**

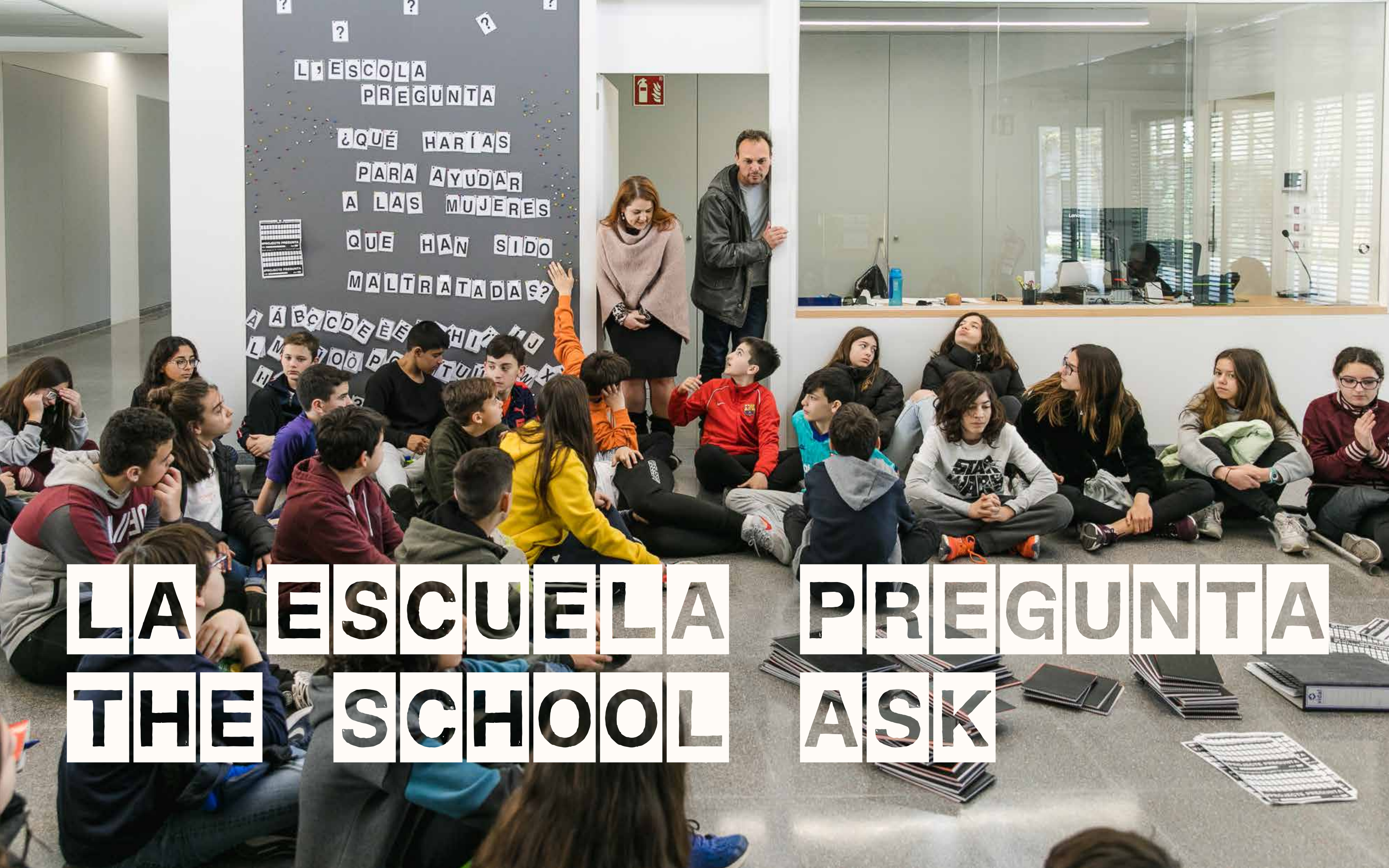

LA ESCUELA  
PREGUNTA

¿QUÉ HARÍAS  
PARA AYUDAR  
A LAS MUJERES  
QUE HAN SIDO  
MALTRATADAS?

A Á B C D E E E H I J U  
L M N O P Q R S T U V W X Y Z

**LA ESCUELA PREGUNTA**  
**THE SCHOOL ASK**

PER QUÈ NO

Teatre

L'Hisà

HA

IGUALTAT?

¿QUÉ PREGUNTA ES URGENTE HACER EL DÍA INTERNACIONAL DE LA MUJER TRABAJADORA?



# PUBLIC INTERVENTION



# DEVICES



# WORK



# SHOP



# FARO+QUARTEIRA+CARTAXO - PORTUGAL





**DUBLIN 2018**

DUBLIN FRINCH FESTIVAL

2018

**WHAT  
NEXT?**

**WHAT WOULD YOU ASK TO EUROPE?**

Sandymount Beach



**WHAT WOULD YOU ASK YOUR BODY?**



8 TRIGGERS QUESTIONS CONFRONTED



**INSTALLATION/** ON THE NORTHERN AND SOUTH SIDE OF THE RIVER LIFFEY



NORTH SIDE →



← SOUTH SIDE

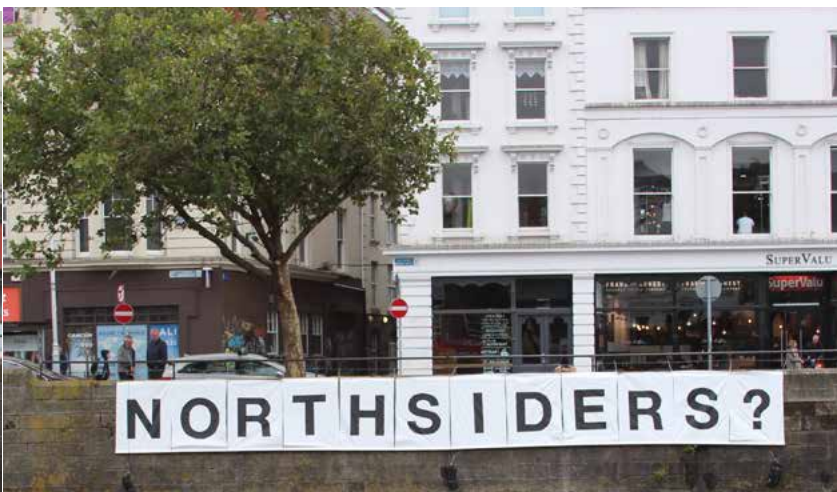

SOUTH SIDE →



← NORTH SIDE



SOUTH SIDE →

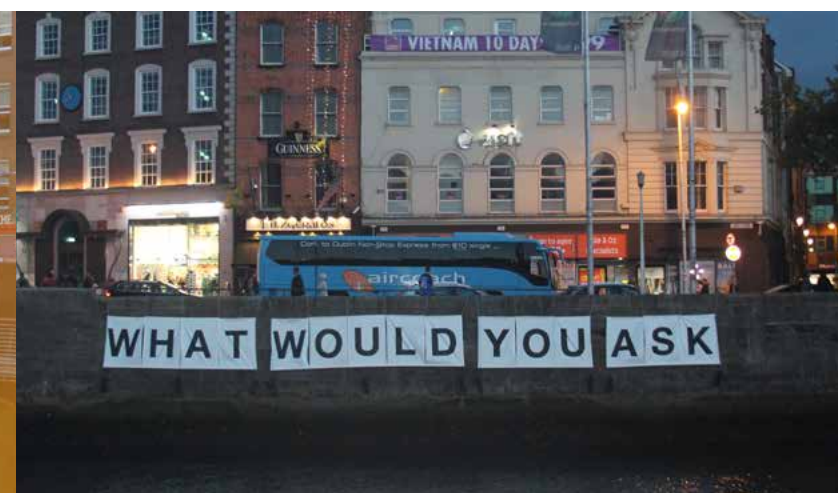

← NORTH SIDE

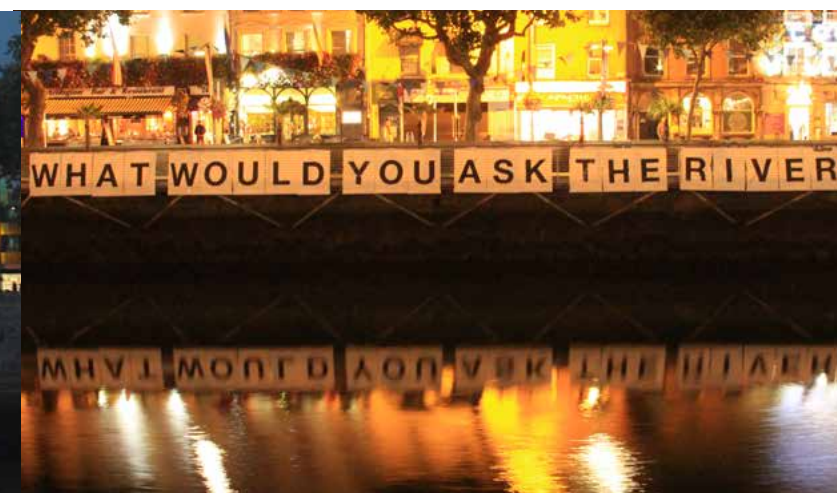

SOUTH SIDE →



← NORTH SIDE



SOUTH SIDE

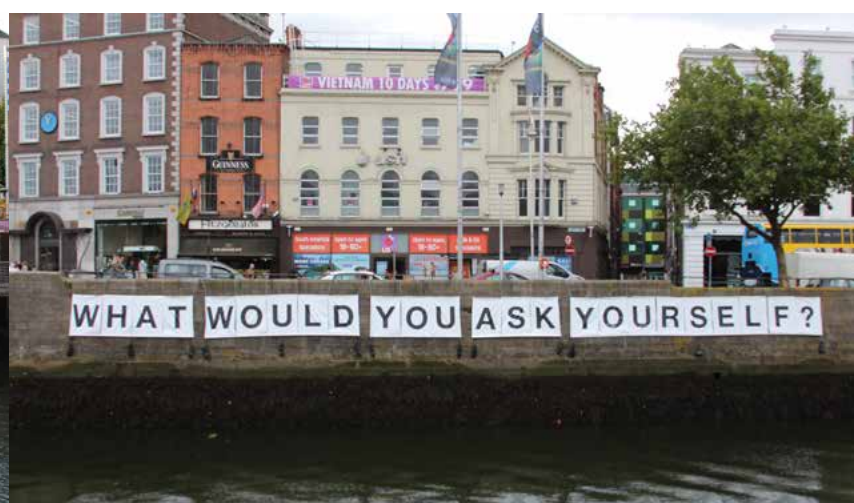

← NORTH SIDE



THE INSTALATION DESTROY BY THE WIND

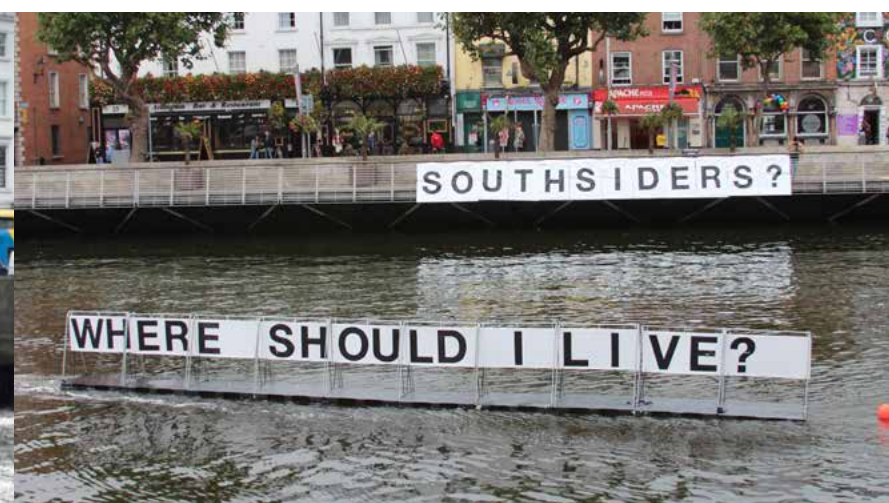

← NORTH SIDE

# INTSTALATION TIME LINE / 8 TRIGGERS QUESTIONS CONFRONTED SOUTH AND NORTH SIDE OF THE LIFFEY RIVER



DUBLIN PORT →



→ GRAND CANAL DOCK? →



→ GRAND CANAL DOCK →



→ QUAY GLOBAL PAYMENTS - REALEX PAYMENTS LTD →



DIVING BELL →



→ BECKET BRIDGE →



→ THE CONVENTION CENTER DUBLIN →

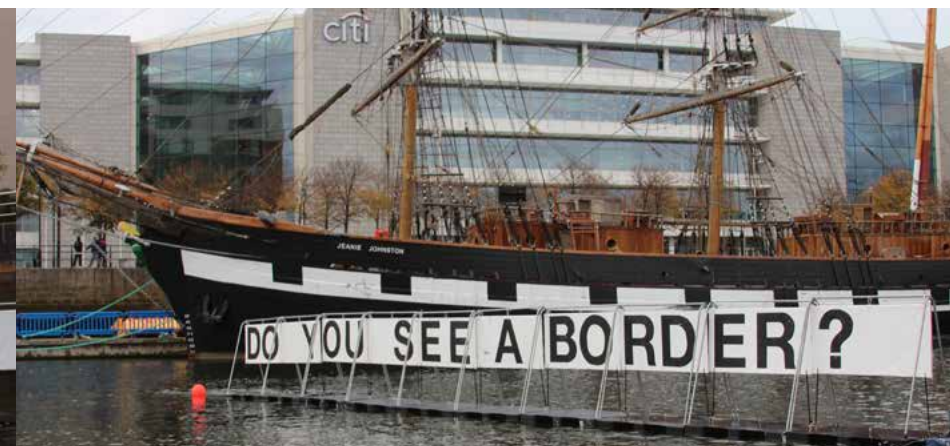

→ JEANIE JOHNSTON TALL SHIP MUSEUM & CITY BANK →



→ THE CUSTOM HOUSE →



→ BUTT BRIDGE →



→ O'CONNELL BRIDGE →



→ DUBLIN DISCOVERED BOAT TOURS →



→ BACHELORS WALK →



→ HA'PENNY BRIDGE →



→ WELLINGTON QUAY →

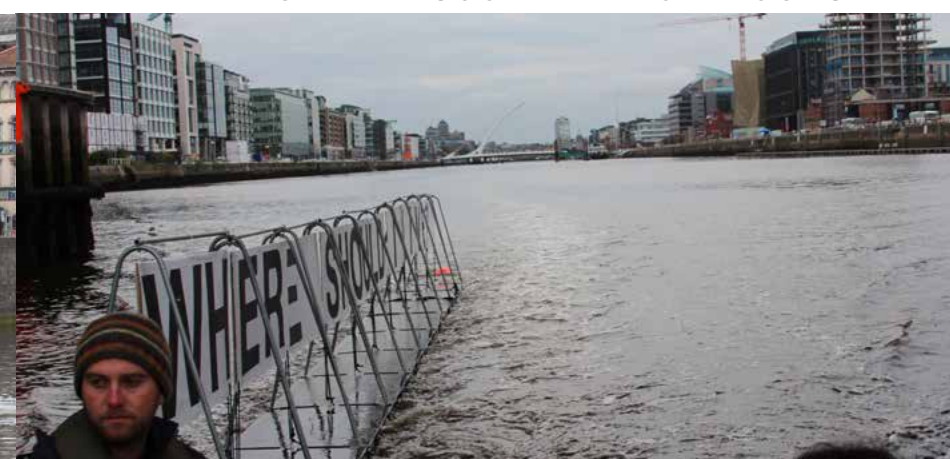

→ WELLINGTON QUAY →

**ACTION TIME LINE** / WHAT WOULD YOU ASK TO THE NORTH?  
WHAT WOULD YOU ASK TO THE SOUTH?

1. WHAT WOULD YOU ASK TO YOUR NAIBOR?



MERRION SQUARE

2. WHAT WOULD YOU ASK TO DUBLIN?

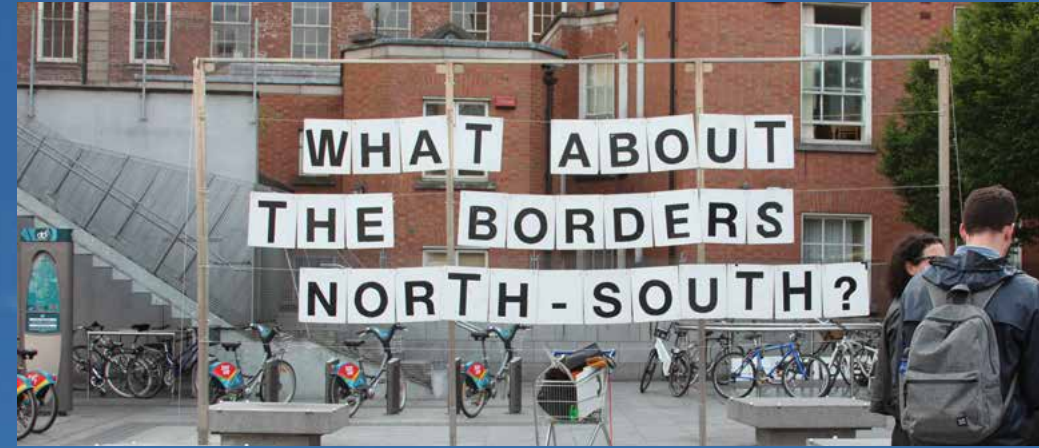

BARBARDO SQUARE

3. WHAT WOULD YOU ASK TO YOUR SELF?



TEMPLE BAR

4. WHAT WOULD YOU ASK TO YOUR EUROPE?



SANDYMOUN BEACH

5. WHAT WOULD YOU ASK YOUR BODY?



HENRY STREET

6. WHAT WOULD YOU ASK THE LANDLORD?



GRAFTON STREET

7. WHAT WOULD YOU ASK YOUR THE RIVER??



O'CONNELL BRIDGES

8. WHAT WOULD YOU ASK TO THE SOUTH/ NORTH?



LIFFEY RIVER

TRIGGERS QUESTIONS AND LOCATIONS



# PUNTA ARENAS

¿POR QUÉ  
ME COMPLICÓ  
TANTO CON  
LAS COSAS?



¿¿¿¿¿QUÉ LE PREGUNTARÍAS A TU CIUDAD??¿¿¿¿¿QUÉ LE PREGUNTARÍAS A MAGALLANES??¿¿¿¿¿QUÉ LE PREGUNTARÍAS A TU VECINO ????????



?????WHAT WOULD YOU ASK YOUR CITY????WHAT WOULD YOU ASK MAGALLANES???WHAT WOULD YOU ASK YOUR NAIBOR?????????



?WHAT WOULD YOU ASK YOUR parents??WHAT WOULD YOU ASK YOUR UNIVERSITY???WHAT WOULD YOU ASK YOUR GOVERNMENT???



????QUÉ LE PREGUNTARÍAS A TUS PADRES ??QUÉ LE PREGUNTARÍAS A TU UNIVERSIDAD ???¿QUÉ LE PREGUNTARÍAS A TU GOBIERNO???????

WHAT WOULD YOU ASK TO YOUR GOVERNMENT?





MADRID  
2018



¿NOS ATREVEREMOS  
A HACER LO QUE  
DECIMOS?

\* VILLVERDE (SAN CRISTÓBAL): MERCADILLO DE LA CALLE BURJASOT, PLAZA PALOMA ¿QUE LE PREGUNTARIAS A

ORCASURW PLAZA DEL PUEBLO¿QUÉ LE PREGUNTARIÁS A TU BARRIO?



TRES  
MERCADILLOS  
DE  
MADRID

GORDA, CONGOSTO / ¿QUÉ LE PREGUNTARIÁS A TU MADRE O TU PADRE ?\*USERA: MERCADILLO DE LA AVENIDA

TÚ CIUDAD ?\* VILLA DE VALLECAS: MERCADILLO DE LA CALLE SIERRA





PLAZA DE ESPAÑA → what would you ask to the future ?

→ ¿dejaran algunos hombres tranquilas a las mujeres

→ ¿nos atrevemos a hacer lo que decimos?

→ SENADO



PALACIO REAL DE MADRID → ¿nos atrevemos a hacer lo que decimos? →

→ ¿por qué?

→ ¿cuanto le queda...

→ ¿por qué?



PLAZA DE ISABEL II →

→

→ ¿cuanto le queda al trap?

→

PLAZA MAYOR → ¿para que?



PLAZA MAYOR → ¿para que vivimos?

→ ¿para que vivimos?

PUERTA DEL SOL → ¿es todo una gran simulación Holográfica? →

→

# ROUTE TIME LINE / WHAT YOU'D YOU ASK THE FUTURE?

#PROYECTO PREGUNTA



# OPEN ARCHIVE MADRID



ESSEN



KÖNNEN MASCHINEN UNS JEMALS ERSETZEN ?



PALMA  
2017

WHAT WOULD YOU ASK TO CULTURAL INSTITUTIONS?

REFUGEES WELCOME.  
TOURISTS GO HOME?







R I O  
2 0 1 5

Q QUE VOCE PERGUNTARIA AOS  
CARIOCAS ?

WHAT WOULD YOU ASK YOUR CARIOCAS?

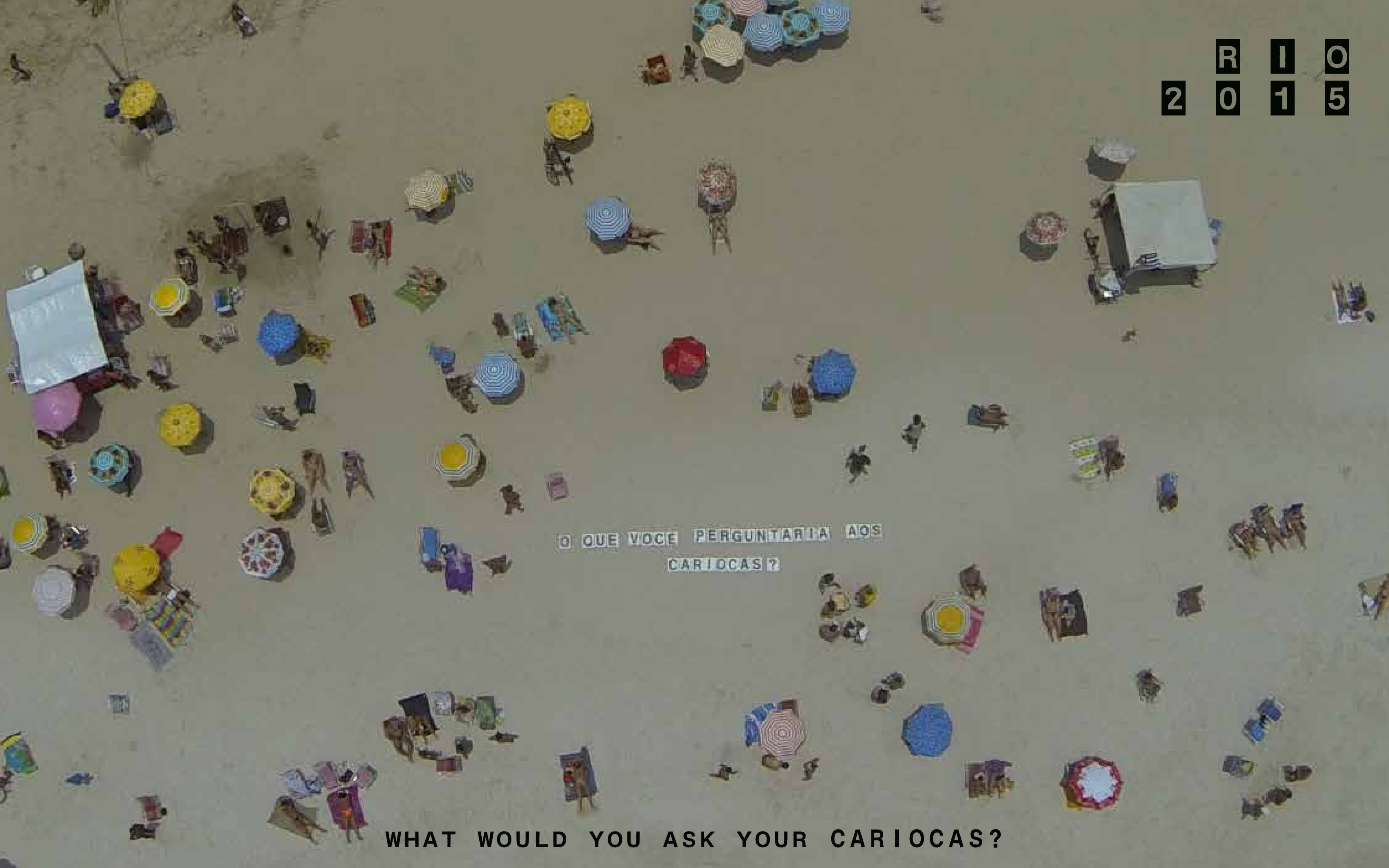





DRESDEN  
2015



#FRAGE PROJECT#FRAGE PROJECT#FRAGE PROJECT#FRAGE PROJECT#FRAGE PROJECT



What would you ask to Europe?



#FRAGE PROJECT#FRAGE PROJECT#FRAGE PROJECT#FRAGE PROJECT#FRAGE PROJECT#FRAGE PROJECT



\*DRESDEN\*DRESDEN\*DRESDEN\*DRESDEN\*DRESDEN\*DRESDEN



WHAT WOULD YOU ASK GERMANY? **WAS WÜRDEST DU DEUTSCHLAND FRAGEN?**



WHAT WOULD YOU ASK EUROPA? **WAS WÜRDEST DU EUROPA FRAGEN?**



¿POR QUE SIGUES  
TIRANDO CEMENTO  
EN TUS PLAZAS?

...COPRINTA  
...ESTÁ...  
...PLAZA...  
...TANTO...  
...TANTO...  
...TANTO...  
...TANTO...







¿QUE LE PREGUNTARÍAS A TU PADRES? #PROVECTOPREGUNTA



-DAD ARE YOU DARK VADER? -DAD ARE YOU DARK VADER? -DAD ARE YOU DARK VADER? -DAD ARE YOU



WHAT WOULD YOU ASK YOUR PARENT?



**BERLIN  
2018**



HOW EXPENSIVE  
WAS THE APARTMENT  
2 YEARS AGO?

WHAT WOULD YOU ASK THE LANDLORD?

ort zw  
Brücke



WHAT WOULD YOU ASK THE LANDLORD? **WAS WÜRDEST DU VERMIETER FRAGEN?**



WARUM?\*WHY?\*¿PORQUÉ? WARUM?\*WHY?\*¿PORQUÉ? WARUM?\*WHY?\*¿PORQUÉ? WAI



WHAT WOULD YOU ASK FUTURE ? **WAS WÜRDEST DU DEINE ZUKUNFT FRAGEN?**



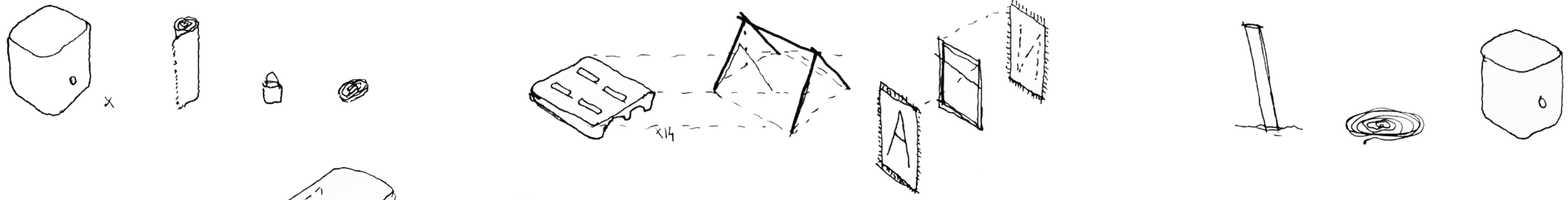

# H O R I Z O N

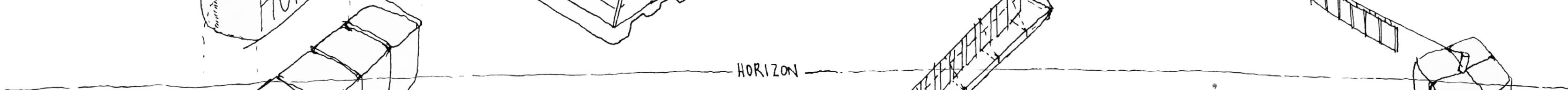
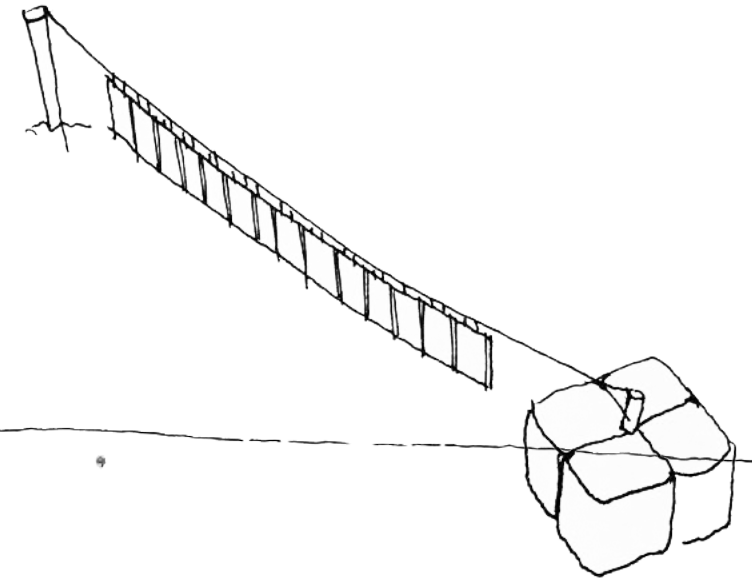
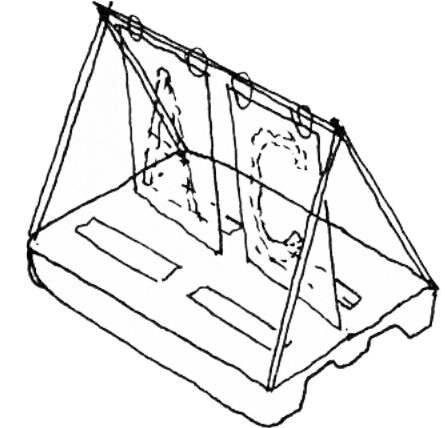
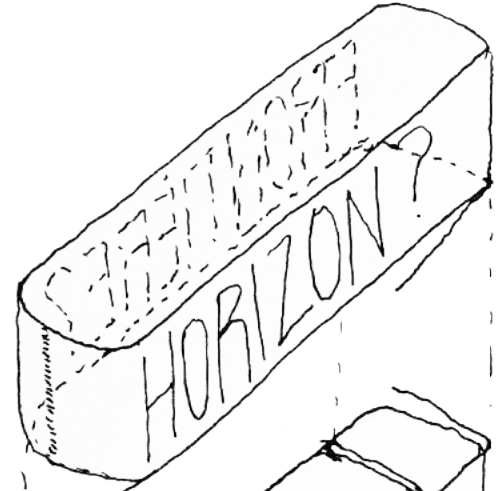

GEOGRAPHICAL      POLITICAL      OF THE BODY  
CURVE      LINE      LIMIT      BORDER      SOVEREIGNTY      COMMUNITY      GAZE

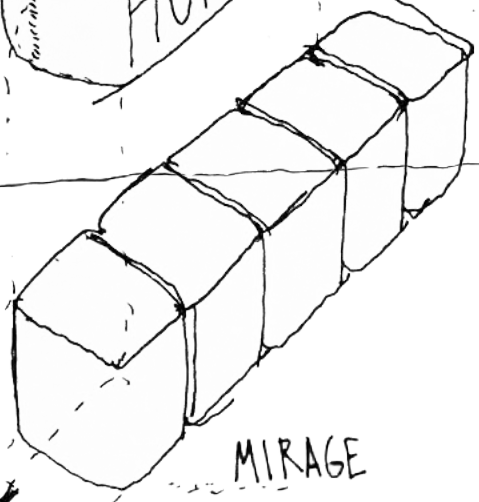

UNATTAINABLE THRESHOLD

SHARED VIEW      SOCIAL AGREEMENT

PUBLIC DEBATES

PUBLIC SPACES

PHYSICAL DISPLACEMENT

COMMUNAL HABITS

UTOPIA

FUTURE

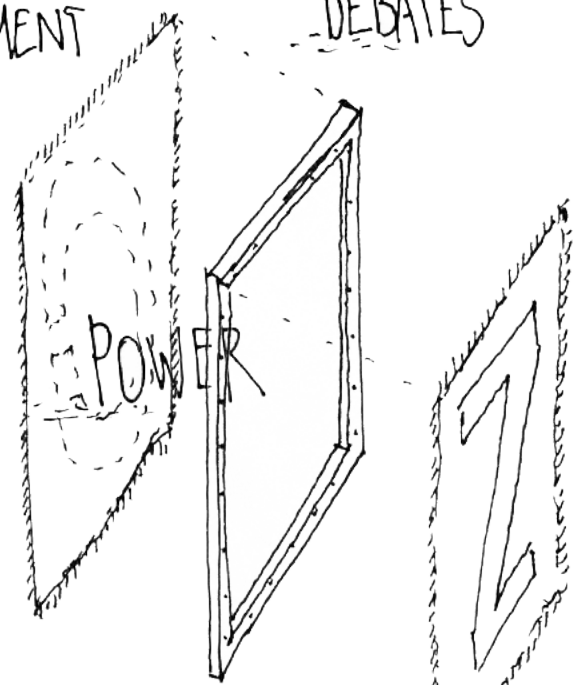

COMMUNICATION

PERFORMANCE

WHAT WOULD YOU ASK THE HORIZON?

ÇA VOUS DIT QU'ON PARTAGE TOUT ?

COMMENT LE FAIRE?

**WE NEED  
A BOAT  
FOR AN  
ART  
PROJECT**

INFO@MILM2.COM  
079 917 28 01

COMMENT LE FAIRE?

**HORIZON?**

WHAT WOULD YOU ASK THE BORDER?



## **FESTIVAL & BIENALES**

- Festival de las artes de Valparaíso 2013 (CL)
- Festival Lollapalooza 2014 (CL)
- Festival Espacios Revelados 2014 (CL)
- Habitat III Naciones Unidas 2016 (EC)
- Festival de los cielos del infinito 2016 (CL)
- Ch.ACO Art Fair 2015 (CL)
- Circuito de las artes Sesc 2017 (BR)
- Far Festival 2017 (CH)
- Fringe Dublin 2018 (IE)
- Claiming for common spaces HAU II 2018 (DEU),
- Projecto Brasil Hellerau Europäisches Zentrum der Künste 2014(DEU)
- Now Play This Festival 2022 (UK)
- Hablar en Lenguas 12º Bienal de Artes Mediales 2015 (CL)
- Feria de Arte Impreso Impresionante Emergencia 2020 (CL)
- Bienal de dança SESC Campinas Sao Paulo 2017 (BR),
- XX Bienal de Arquitectura y Urbanismo 2017 (CL)
- Festival Salmón 2020 (CAT)
- Festival veranos de la la villa 2019 (ES)
- Verao azul Festival 2019 (PT)
- Materias Diversos Festival 2019(PT)
- Homo Novus Festival 2020 (LV)
- Al aire libre 2020(CL)

## **TALKS & KEYNOTES**

- Ideas City-New Museum 2019 (USA)
- Universität der Künste Berlin 2019 (DEU)
- Columbia GSAP 2017 (USA)
- Universidad Austral de Chile 2019 (CL)
- European Dance Network 2015 (EU)
- Centro nacional de arte Reina Sofía 2019(ES)

## **MUSEUMS/THEATERS/COMMUNITY CENTERS**

- Casa França Brasil (BR),
- Teatre Principal Palma de Mallorca (ES)
- Pasarelas Verdes(CL)
- Hole of Fame (DEU)
- Museo de la solidaridad Salvador Allende (CL)
- Pact-Zollverein performing artschoreographisches zentrum(DEU)
- Humboldt Forum (DEU)
- Museo interactivo Mirador(CL)
- Teatre Artesà(CAT)
- Casa Quien (RD)
- Centro nacional de arte Reina Sofia(ES)
- Galería Temporal (CL)
- Galería d21(DEU)
- Parque Cultural deValparaíso(CL)
- GAM Centro Cultural Gabriela Mistral (CL)
- Centex Valparaíso(CL)
- Mercats de las Flors(CAT)
- Matadero-Madrid(ES)

-Galeria Monoambiente (AR)

## **RESIDENCIAS**

- Campo Abierto (UY),
- Pact-Zollverein performing arts choreographisches zentrum(DEU),
- Centro Cultural de España Santiago (CL)
- NAVE/ Centro de creación y residencias (CL),
- Far Festival(CH),
- Fringe Dublin (IE)
- Centro nacional de arte Reina Sofía 2019(ES)

## **INSTITUTIONAL PARTNERS**

- NAVE/ Centro de creación y residencias (CL),
- Elige educar (CL),
- Coincidencias Pro Helvetia(CH),
- Graham Foundation for Advanced Studies in the Fine Arts(USA)
- Centro nacional de documentación(-CL),
- Fundación Fava(CL)
- Unfinished (US)
- Servivio Pais (CL),
- Consejo Nacional de la cultura y las artes (CL)



CONTACTO

PEDRO SEPÚLVEDA

PEDRO@MILM2.COM

INFO@MILM2.COM

+56988323296

WWW.MILM2.COM

INSTAGRAM: @MILM2STGO

- DAJABON(RD) - BARCELONA(CAT)  
- BELLAIRE(US)  
- BERLIN(GER) - BOTACATÚ(BR)  
- CARTAXO(PT) - CASTRO(CL) - DRES-  
DE(GER) - ESSEN(GER) - GUWHATI ASAM(IN)  
IQUIQUE(CL) - ITAQUAQUE  
CETUVA(BR) - ITÚ(BR) - MADRID (ES) -  
MAUÁ(BR) - NUEVA YORK(US) - OLOT(-  
CAT) - OURINHOS (BR)  
- PALMA DE MALLORCA(ES) - PALMI-  
TAL(BR) - PRAT DEL LOBREGAT(CAT)  
- PUNTA ARENAS(CL) - QUARTEIRA (BR) -  
QUITO(EC) - RIGA(LVA) - RIO DE JANE  
IRO (BR) - SAN PEDRO DE MAR-  
CORIS(RD) - SANTIAGO (CL) - SÃO CAE-  
TANO (BR) - SÃO ROQUE (BR) - SÃ PAU-  
LO(BR) - TEMUCO(CL) - TEXAS(US)  
- TIJUANA(MEX)  
- VALPARAÍSO (CL) - VOTORANTIM (BR)  
- WEIMAR (GER) - LEIPZIG(GER) - LON-  
DON(UK) - MONTEVIDEO(UY) - NYON(SW)  
- RIBERA(UY) - SANTIAGO(CL)  
- SANTO DOMINGO(RD)